



YORKSHIRE RUBBER LININGS LTD.

Yorkshire Rubber Linings Limited is a specialist industrial coatings applicator. We provide a comprehensive range of products for corrosion and erosion protection. We create bespoke products and solutions to satisfy individual client needs. YRL Ltd provide factory applied coatings and on-site inspection, maintenance, repair and overhaul services.



Yorkshire Rubber Linings Ltd, Priestley House, Union Road, Liversedge,
West Yorkshire WF15 7JZ. www.rubberlinings.co.uk

T. 01924 410414 F. 01924 410413 E. sales@rubberlinings.co.uk

With over 28 years of experience and expertise from our central UK operation and unrivalled investment in product development Yorkshire Rubber Linings Ltd is a leading applicator of protective coatings in rubber and composite materials. Processing and Manufacturing industries must continually manage protection of valuable production assets from corrosion and wear whilst avoiding expensive downtime. We strive to reduce downtimes by offering a rapid response to enquiries, new orders and site repairs and overhauls.

Range of services

Rubber Coatings

Roller and drum Covering

Fabrication and machining

Site Service and Repair

Rubber and Allied Products

Emergency Shut-Down Services

Transport and Packaging

Environmental Reclamation Services

Glass Flake, Epoxy & Polyurethane Resin Coatings



OUR EXPERTISE



RUBBER LINING



Fully bonded, vulcanised linings for plant and equipment encountering arduous conditions such as: Corrosion; Chemical Attack; Abrasion & Wear; Weathering; Ozone; Vandalism; Acids or Alkalis; Oils or Grease; Sea Water

Rubber Linings also applied for: Sound Absorption; Thermal Insulation; Aesthetic Finish; Electrical Insulation or Conductivity; Food & FDA Approval; Potable Water Approval

Wide range of Rubber Compounds to suit many different applications...

Hard Ebonite (Vulcanite)

Soft natural Rubber

SBR

Neoprene, (Chloroprene)

Nitrile

Hypalon

Butyl

EPDM

(Other compounds by request)

Available in Black, White, Drab, (off-white), and a large range of colours. Please contact us for more details.

Thickness range - 1mm to 50mm dependant upon application and substrate design.

New and Used Equipment Treated - Old worn coatings can be removed and metal parts refurbished and prepared for a new covering to save time and money.



HIGH PERFORMANCE INDUSTRIAL COATINGS FOR CHEMICAL, CORROSION AND ENVIRONMENTAL PROTECTION

Composite Coatings and Repair Systems for metal and concrete surfaces and equipment operating in a wide range of industrial conditions. Yorkshire Rubber Linings Ltd provide coatings solutions and repair systems designed to meet exacting requirements in a diverse range of industries including: Marine; Power; Oil & Gas; Chemicals; Nuclear; Mining; Minerals; Processing; Water Treatment; Manufacturing and Engineering.

Composite Coatings

•Yorkshire Rubber Linings Ltd apply a wide range of high performance coatings in their factory and on customer sites, including:

Resimac Products

•Range of metal, ceramic and concrete coating products manufactured by Resimac Ltd.

Chemco Coatings

•Glassflake and Epoxy coating and repair systems manufactured by Chemco International Ltd in Scotland.

Belzona Polymeric Products

•YRL are approved applicators of the wide range of epoxy based Belzona industrial protection and repair products.

3M Scotchkote Products

•Fusion Bonded Epoxy coatings; specialist powder coatings

The above are just some of the systems applied and many others are available including those manufactured by PPG, Sherwin-Williams, Jotun, Corrocoat, Rema Tip Top.

Other Products

•2-pack Epoxy, Acrylic Urethane, Zinc Prime and polyurethane Coatings.

•Glass Fibre Reinforced Plastic, (GRP), Coatings

•Rubber and Ebonite repair kits

•Epoxy Resin Screed Coatings

•Industrial flooring and tiling.

High Performance Industrial Paint Systems for chemical, corrosion and environmental protection

Brush or Spray applied industrial paint systems including 2-pack Epoxy, Acrylic Urethane, Zinc Primers, Coal Tar Epoxies and Marine Coatings.



Epoxy Paint Applications

Industrial surfaces are subjected to numerous adverse conditions on an ongoing basis; our Two Pack Paint systems provide essential coating and protection for many industries and commercial operations.

Our systems are designed to cover a range of needs and applications from protective to decorative. Painting of pipework forms a significant part of the work undertaken by YRL. Whether reclaiming existing corroded pipework or coating new, we have the experience and facilities to carry out major projects as well as individual pipe spools.



FABRICATION SERVICES

As part of our service we can remove any existing lining and repair any part of the metal substrate, which has suffered corrosion, mechanical or abrasion damage.

New metal fabrication, large or small, can be supplied where a complete unit including rubber lining is required.

Our service includes full project management from design and drawings to manufacture and if required, installation.

We can offer CAD drawings; repair and replacement parts and special alloys such as Hastaloy and Incaloy where rubber lined products are not suitable.

Fully qualified personnel to ASME and BS specifications carry out all our fabrications.

We provide a wide variety of field services and repair work including fabrication and welding.



BUND LINING

Effective bunds should be in good repair, of adequate size and completely watertight.

Each Industrial bund lining project is assessed on its individual needs depending on the primary containment, overall condition, and location.

Our linings and coatings are applied to existing bund walls and floors using a hand lay-up or spray or brush system.

A lining systems creates a completely seamless membranes: sealed environments that are oil and water tight containing any potential diesel, fuel, chemical or oil leaks or spillages within the bund.

Refurbishing your bund with our protective linings is the long term cost effective solution satisfying you and the environment.

Our inspectors have decades of experience within the industry and are experts in their field. We provide detailed reports with recommendations for the future use of any inspected bund.



ROLLER AND DRUM COVERING

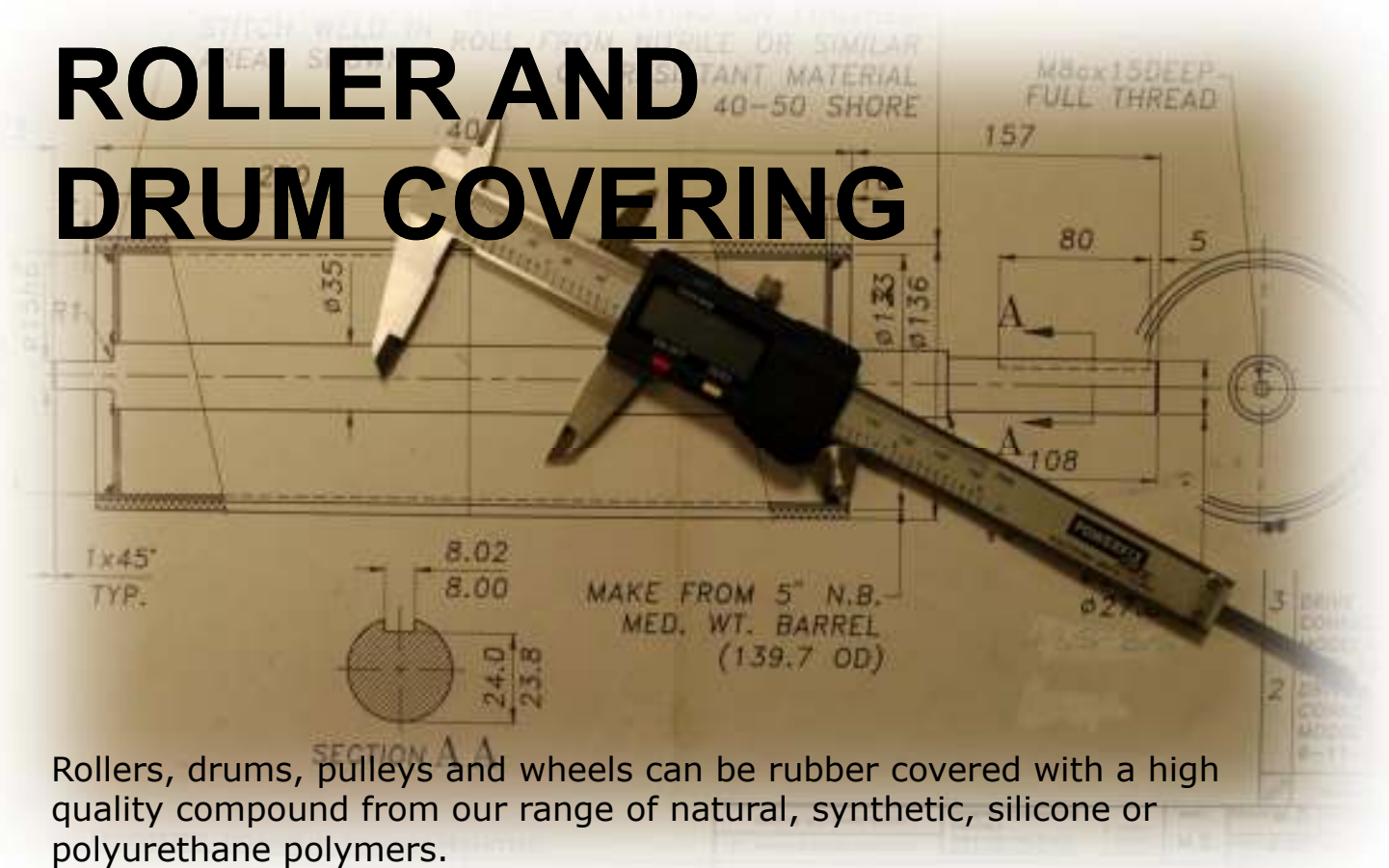

Rollers, drums, pulleys and wheels can be rubber covered with a high quality compound from our range of natural, synthetic, silicone or polyurethane polymers.

Our experience can match your particular application with the correct type of rubber, hardness and finish that will give you the optimum performance.

When your situation demands a new roller or drum, or when refurbishment is not appropriate, let Yorkshire Rubber Linings Ltd quote you for the complete supply of a newly manufactured unit with a rubber covering to suit its duty.

Profiles are machined using state of the art equipment. Sophisticated software ensures a profile with an unrivalled degree of accuracy. Our services includes stripping and replacing of worn coverings within a time-frame designed to minimise your plant's downtime.

Refurbishments also helps to keep costs down by extending the life-span of your roller and drum metals.

WORKSHOP CAPABILITIES

Yorkshire Rubbers Linings Ltd' facility is located in the heart of West Yorkshire and within 2.5 miles from the M62 and the M1. Yorkshire Rubber Linings Ltd is one of the few rubber lining and coating workshops in UK with a facility that can process large equipment. 20,000 square feet of lining and coating space, a 15ft 8" wide x 8ft 10" high x 22ft long abrasive blasting booth, 2310mm wide x 2300 high x 6300mm long pyrolysis oven and a large outside storage area. Yorkshire Rubber Linings Ltd can handle customers goods both large and small. We also have a range of steam autoclaves at our facility enabling us to handle various vulcanizing requirements.

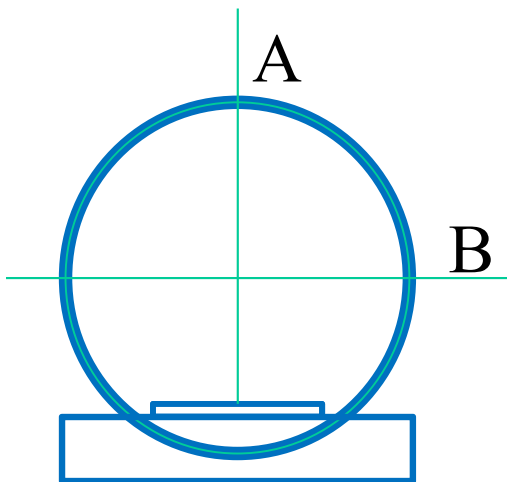

AUTOCLAVE CAPABILITIES

	A	B	Length
Autoclave 1	2515mm	3048mm	6800mm
Autoclave 2	1930mm	2286mm	6096mm
Autoclave 3	1255mm	1500mm	4400mm
Autoclave 4	350mm	500mm	14630mm

Equipment that is larger than our autoclaves can still be rubber lined and cured. This is carried out by exhaust steam curing or by the use of custom made steam boxes.

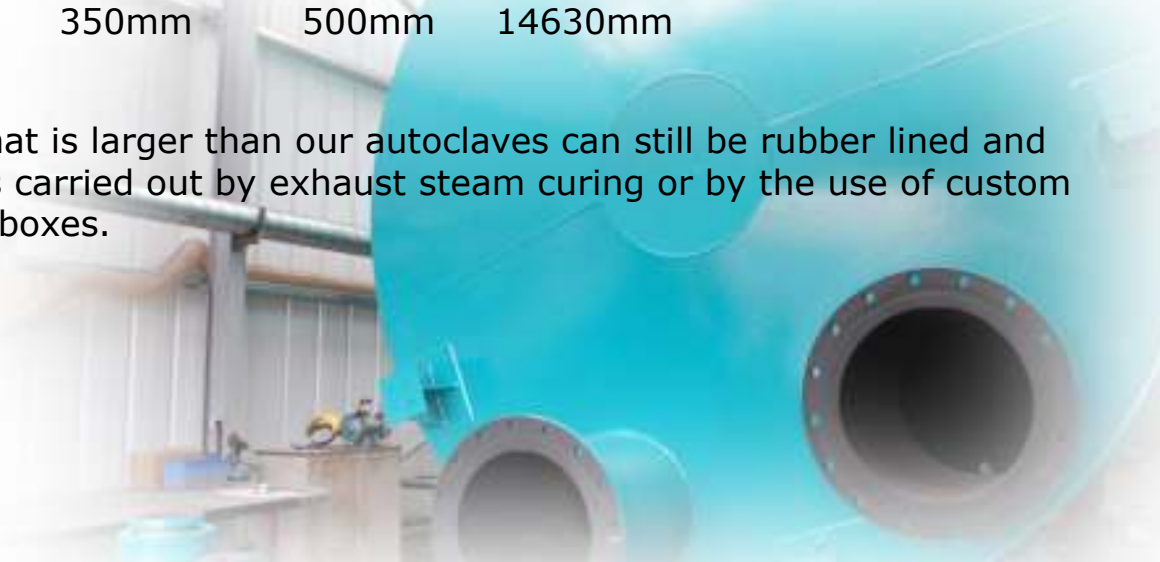

SITE SERVICE



Yorkshire Rubber Linings Ltd has wide industrial experience of applying and repairing protective coatings and linings in the field. We commonly carry out repairs at facilities such as nuclear and conventional power plants, chemical process plants, municipal water treatment facilities, oil fields, mines and other locations. With ageing infrastructure, refurbishment of existing equipment is our most common challenge in the field. Yorkshire Rubber Linings Ltd provides cost effective solutions to keep ageing equipment in service.

Our field services include:

- Field fabrications
- Repairs and modifications
- 24 hour emergency response services
- Linings and coatings
- Inspections
- Spark testing
- Preventative maintenance

Approved Applicators

On site maintenance and repairs involve many different linings and coatings. Yorkshire Rubber Linings Ltd are approved applicators for Resimac and Belzona.



TANKER SERVICE

Yorkshire rubber Linings Ltd can carry out full inspections and repairs to your road tankers and equipment, repairs can be carried on our site at Spenborough Works or carried out at on a site of your choice subject to the type of repair required. We can also offer an option to fully refurbish existing rubber lined tankers at our Spenborough Works, offering you a lower cost option than buying new or used units.

Inspections

Inspections carried out by our trained inspectors include a full visual, hardness, thickness and spark test. This is followed up by a full detailed report that includes recommendations for any repairs that require attention. Inspections can be carried out on site at your premises or at our site.

Repairs

Inspected tankers that require repairs can be processed at our Spenborough Works or in some cases at client facilities. We can carry out inspection and repairs on both Rubber and glassflake lined tankers.

Full Refurbish

If a tanker is beyond repair and has come to the end of its working duty Yorkshire Rubber linings can carry out a full refurbish of your road tanker. This includes the removal of the old lining via water jet stripping prior to the shotblasting of the tanker ready for the new rubber lining to be applied. Full refurbishment of the road tanker can only be carried out at our works and not on site.



CUSTOMER SUPPORT



Technical Support and Coatings Application Advice

We pride ourselves in providing excellent free technical support for all Rubber or Corrosion Products. We can provide direct personal, email or telephone assistance to help you satisfy your particular need.

Quotations | Free quotations within 24 hours

For a free quote you simply email our sales department and one of our representatives will contact you shortly. You can also call us at 01924 410414 or fax on 01924 410413

Accounts | Invoices, Accounts payable & Credit Application

For support or queries regarding Invoices please contact our Accounts department, you can also download our PDF Credit Application and Standard Terms and Conditions form our website.

Customer Satisfaction | Customer Satisfaction & Customer Complaints

The quality of our application and service is second to none, but we realise that occasionally you may wish to raise your own concerns. If you are currently experiencing problems and require urgent customer support please call us on 01924 410414.